



# DSL

Digital Subscriber Line

**tutorialspoint**

SIMPLY EASY LEARNING

[www.tutorialspoint.com](http://www.tutorialspoint.com)



<https://www.facebook.com/tutorialspointindia>



<https://twitter.com/tutorialspoint>

## About the Tutorial

---

Digital Subscriber Line (DSL) technology is a copper loop transmission technology, which satisfies bottleneck problems often associated with the last mile between the network and the service providers.

This is an introductory tutorial, which covers the basics of the DSL Technology.

## Audience

---

This tutorial is created for engineers who are new to the DSL Technology. This tutorial provides simple, easy to understand explanations with useful working examples. We will go through most of the modules of DSL, so the reader can also use this as a reference for their projects.

## Prerequisites

---

There are no specific prerequisites for understanding this tutorial. It will be helpful for the readers, if they are from the telecommunications background. Additionally, it will be advantageous if the reader knows the various equipment used in DSL, its protocols and configurations and other related technologies.

## Copyright and Disclaimer

---

© Copyright 2017 by Tutorials Point (I) Pvt. Ltd.

All the content and graphics published in this e-book are the property of Tutorials Point (I) Pvt. Ltd. The user of this e-book is prohibited to reuse, retain, copy, distribute or republish any contents or a part of contents of this e-book in any manner without written consent of the publisher.

We strive to update the contents of our website and tutorials as timely and as precisely as possible, however, the contents may contain inaccuracies or errors. Tutorials Point (I) Pvt. Ltd. provides no guarantee regarding the accuracy, timeliness or completeness of our website or its contents including this tutorial. If you discover any errors on our website or in this tutorial, please notify us at [contact@tutorialspoint.com](mailto:contact@tutorialspoint.com)

## Table of Contents

---

About the Tutorial .....	i
Audience.....	i
Prerequisites.....	i
Copyright and Disclaimer .....	i
Table of Contents .....	ii
<b>1. DSL – Overview .....</b>	<b>1</b>
<b>2. DSL – Basics.....</b>	<b>3</b>
Basic DSL Concepts .....	3
Attenuation & Resulting Distance Limitations.....	3
Advanced Modulation Techniques Minimize Attenuation .....	4
<b>3. DSL – Home.....</b>	<b>6</b>
DSL Technology Options.....	7
Services Offered by DSL Home – TR-69 .....	9
TR-064 LAN Side CPE .....	13
Use Cases for DSL Home Services.....	14
DSL Home Roadmap .....	15
TR-69 vs SNMP.....	16
<b>4. DSL – System Components.....</b>	<b>19</b>
Transport System.....	19
Local Access Network.....	19
Multiservice DSLAM .....	19
DSL Modem/Router.....	20
POTS Splitters and Microfilters.....	21
<b>5. DSL – ADSL Fundamentals.....</b>	<b>22</b>
ADSL Fundamentals.....	22
ADSL Standards.....	23
Dial Tone Services.....	25
Application Switch from Video to Data .....	25
Optimization for Data Services .....	25
RADSL Standards .....	26
G.lite for the Consumer Market .....	27
Why ADSL2? .....	28
WHY On-Line Reconfiguration? .....	30
<b>6. DSL – VDSL Access Technology .....</b>	<b>39</b>
Asymmetric VDSL .....	40
Symmetric VDSL .....	40
<b>7. DSL – VDSL-based Service Sets .....</b>	<b>42</b>

<b>8. DSL – VDSL-based Video Services .....</b>	<b>43</b>
High-Speed Internet .....	43
Telephony Services .....	43
Deployment Scenarios.....	44
Major VDSL2 Activity .....	44
VDSL2 Key Features .....	45
VDSL2 – DMT (Discrete Multi-Tone).....	46
<b>9. DSL – Questions and Answers .....</b>	<b>48</b>

# 1. DSL – Overview

Digital Subscriber Line technology is a **Copper Loop Transmission Technology**, which satisfies bottleneck problems that are often associated with the last mile between the network and service providers.

While DSL technology provides dramatic improvements in speed, (up to 8+ Mbps) compared to other network access methods, the true strength of DSL-based service opportunities lies in the actions like –

- Multimedia applications required by today's network users.
- Performance and reliability.
- Economics.

As shown in the following sample comparison chart, DSL-based services offer Performance Benefits for the Network Service Users when compared to other network access methods. In Addition, DSL-based services expand these operational improvements for public and private (Campus) operators.

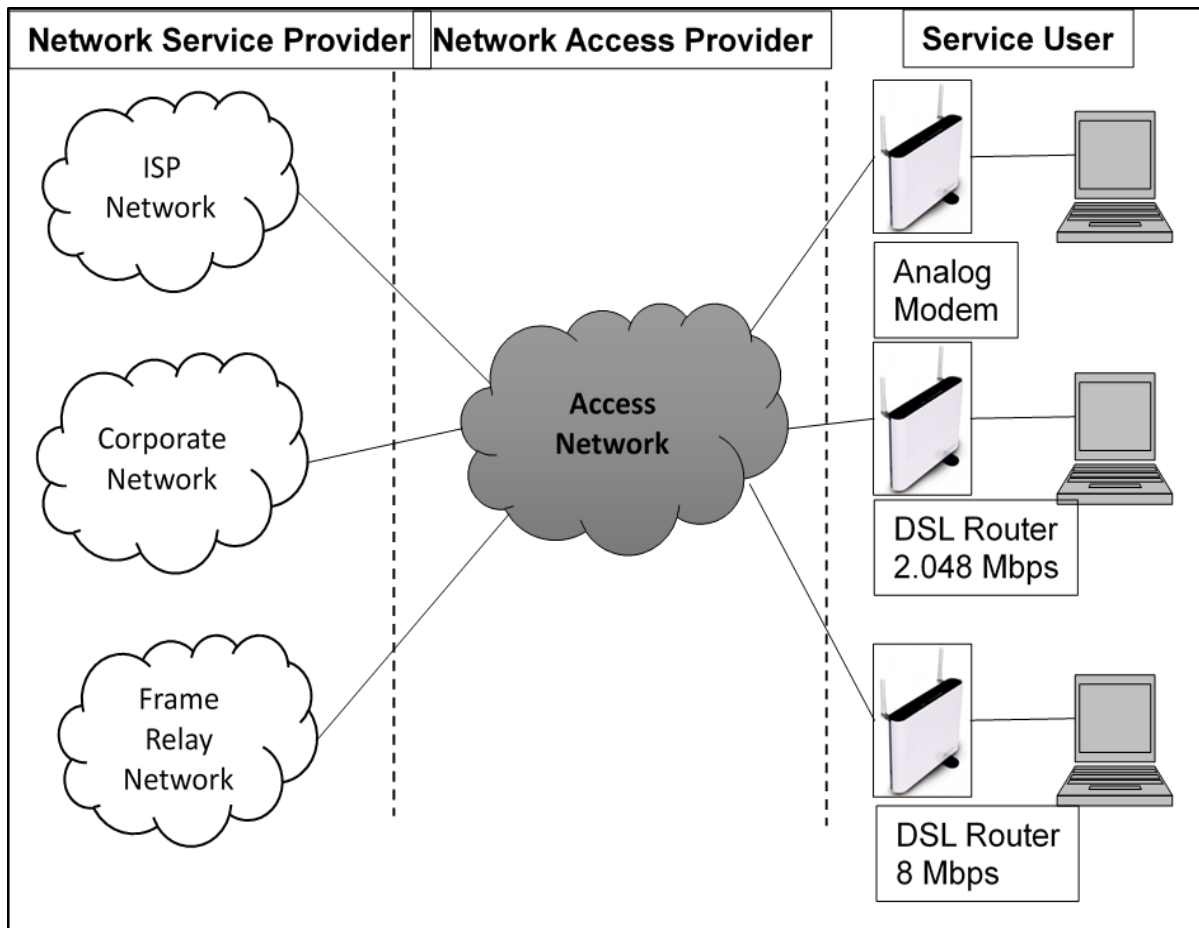

One of the compelling advantages of DSL technology is that it is the NSP and helps the Service Users to take full advantage of the existing infrastructure, layer two and layer three Protocols (such as Frame Relay, ATM and IP), and have reliable network services already entrusted to come.

DSL can easily support advanced business-class services such as **Voice over DSL (VoDSL)** and new variants of proven and well-understood technologies such as the **Frame Relay over DSL (FRoDSL)**. The latest generation of DSL equipment also offers end-to-end **Service Level Management (SLM)**. For simplicity, in our discussion regarding business class DSL applications, we will group all of these under a new acronym: **SLM-DSL**.

## 2. DSL – Basics

A wide range of DSL technologies and DSL products have entered the market, bringing with them both the opportunity and confusion. This chapter provides an overview of the technology, which can transmit information via copper lines and changing various DSL technologies. After understanding this concept, you can be better prepared to assess DSL technology and related products.

### Basic DSL Concepts

---

The PSTN and supporting local access networks have been designed with guidelines that transmissions are limited to an analog voice channel 3400 Hz. For example – **Telephones, Modems, Dial Fax Modem** and **Private Line Modems** have limited their transmissions on local access telephone lines to the frequency spectrum between 0 Hz and 3400 Hz. The highest information rate possible using 3400 Hz frequency spectrum are less than 56 Kbps. So how does DSL achieve information rate in the millions of bits per second on the same copper lines?

The answer is simple – Eliminate the limit of 3400 Hz frequency boundary, much like the traditional T1 or E1, which uses a much wider range of frequencies than the voice channel. Such an implementation requires the transmission of information over a wide frequency range of one of the ends of the copper wire loop to another accessory, which receives the frequency width of the signal at the end of the copper loop.

As we have now understood that we can choose to remove the limit frequency 3400 Hz, and increase the supported information rate on copper son; you may be wondering, "Why not we just ignore POTS guidelines transmission and the use of higher frequencies?"

### Attenuation & Resulting Distance Limitations

---

Let us understand regarding attenuation and the other factors that result in distance limitations.

- **Attenuation** – The dissipation of the power of a transmitted signal as it travels over the copper wire line. In-home wiring also contributes to attenuation.
- **Bridged taps** – These are unterminated extensions of the loop that cause additional loop loss with loss peaks surrounding the frequency of the quarter wavelength of the extension length.
- **Crosstalk** – The interference between two wires in the same bundle, caused by the electrical energy carried by each.

One can compare the transmission of an electrical signal to drive a car. The faster you go, the more energy you burn over a given distance and the sooner you have to refuel. With electrical signals transmitted on a line of copper wire, the use of higher frequencies to support

high-speed services also leads to shorter loop scope. This is because the high frequency signals transmitted by wire loops attenuate energy more quickly than low frequency signals.

One way to minimize attenuation is to use lower resistance wire. Thick wires have less resistance than thin wires, meaning lesser signal attenuation and therefore, the signal can travel a longer distance. Of course, thick gauge wire means more copper, which results in higher costs. Hence, the phone companies have designed their cable plant by using the thinner gauge wire that could support the required services.

## Advanced Modulation Techniques Minimize Attenuation

---

In the early 1980s, equipment providers actively worked to develop basic rate ISDN, which provided up to 64 Kbps two B channels plus one D channel 16 kbps used for signaling and packet data. The payload of the information, and other overhead costs associated with the implementation, led to 160 Kbps in total transmitted information.

A key requirement of ISDN was that it had to reach customers on existing copper, equivalent to 18,000 feet. However, an **AMI Implementation** of basic rate ISDN would require the use of the lower part 160,000 Hz, resulting in too much attenuation of the signal and is below 18,000 feet, which is the necessary loop carried on the wire 26 gauge.

In 1988, advances in signal processing and coding line has doubled the efficiency of the AMI code inheritance by sending two bits of information in each cycle of analog waveform or transmission. The line of code was called **2 binary, 1 Quaternary (2B1Q)**. A 2B1Q implementation of ISDN basic rate uses frequencies ranging from 0 (zero) to about 80,000 Hz, which has less attenuation and results in the desired loop reach of 18,000 feet.

## History about ADSL Line Codes

Around the same time (1980's decade), the industry recognized asymmetric attributes of the local loop that telephone companies had developed a strong interest in providing video entertainment services. This interest has been motivated by the desire to increase revenue through new services and recognizing that non-US cable television operators have started offering voice services over their plant coaxial cable.

By late 1992, three line codes were emerging as the most likely technologies to support high-speed video dial tone services. These were:

- **QAM**, or Quadrature Amplitude and Phase Modulation, a line coding technique used in modems for over 20 years.
- **CAP**, which was introduced earlier for HDSL and is actually a variant of QAM.
- **DMT**, or Discrete MultiTone, a line coding technique that was patented (but not implemented) by AT&T Bell Labs over 20 years ago.

Unlike 2B1Q, which is a baseband technology that transmits at frequencies, which include 0 Hz or DC, the line codes mentioned above are typically bandwidth and may be designed to operate in any frequency range specified.



DSL was originally designed as a residential service that needs to coexist independently with the POTS already provisioned. Therefore, the bandwidth attributes were considered a prerequisite for the frequency separation between FDM or POTS, a user upstream channel service on the network, and a downlink from the network to the user services.

In addition to the implementation of FDM above, some DSL technologies, including some implementations of DMT, were designed to provide an echo canceller of the upstream and downstream channels to minimize the use of frequencies more high and optimize loop reach. However, some observers believe that the performance of these systems echo canceled, tend to deteriorate. A growing number of similar services are deployed in the same cable bundle, offsetting the substantial gains associated with avoiding higher frequencies.

# 3. DSL – Home

DSL Home is an initiative taken by DSL-Forum. The following points will describe its various features and advantages.

- To define requirements related to home devices like residential gateways, VoIP devices and local & remote management of home devices.
- To enable triple/quad play services to the end-user(s) like voice, video, data, including IPTV, video on demand, content on demand, etc.
- DSL Home remote management protocol (TR-69) and its extensions are access agnostic.
- Remote Management **is the core** of DSL Home or next generation Residential Gateway (RG) & in-home networking.
- DSL Home group has come up with the standards for CPE requirements and management of the CPE devices.
- Standards defining requirements:
  - **WT-124: Issue 2 of TR-068:** Residential Gateway defining complete RG requirements that not specific to DSL but includes other access technologies like xPON.
  - **TR-122** defines Voice ATA Requirements.
- Standards in management framework:
  - **TR-64:** LAN Side CPE Configuration and Enhancements.  
For configuration and management of CPE devices via local LAN interface.
  - **TR-69:** CPE Wan Management Protocol  
For configuration and management of the CPE device through remote side.
  - **TR-111:** allows TR69 remote management for the devices in the Home Network (HN).
  - **TR-98 and TR-133:** Configuration and Management of Service differentiation (QoS) parameters in the CPE devices through TR-69 and TR-64 respectively.
  - **TR-104** Data model for VoIP services  
Extended for Video services too.

- **TR-106** defines the common data model template  
Defines the baseline object structure and a set of accessible parameters for a TR-69 device.
- **TR-122** defines Voice ATA Requirements.
- **WT-135:** object model for the STB devices.
- **WT-140:** object Model Network Storage Devices.
- **WT-142:** Framework for TR-069 enabled PON devices.

## DSL Technology Options

The following table describes the various DSL Technology options in detail.

Family	ITU	Name	Ratified	Maximum Speed capabilities
ADSL	G.992.1	G.dmt	1999	7 Mbps down 800 kbps up
ADSL2	G.992.3	G.dmt.bis	2002	8 Mb/s down 1 Mbps up
ADSL2plus	G.992.5	ADSL2plus	2003	24 Mbps down 1 Mbps up
ADSL2-RE	G.992.3	Reach Extended	2003	8 Mbps down 1 Mbps up
SHDSL (updated 2003)	G.991.2	G.SHDSL	2003	5.6 Mbps up/down
VDSL	G.993.1	Very-high-data-rate DSL	2004	55 Mbps down 15 Mbps up
VDSL2 -12 MHz long reach	G.993.2	Very-high-data-rate DSL 2	2005	55 Mbps down 30 Mbps up

VDSL2 - 30 MHz Short reach	G.993.2	Very-high-data-rate DSL 2	2005	100 Mbps up/down
-------------------------------	---------	---------------------------	------	------------------

## Convergence at Home

Multiple broadband and networking technologies are converging in the next generation digital home, such as –

- ADSL2/ ADSL2 Plus / VDSL2 / xPON.
- Wireless/Ethernet/USB/HomePlug A/V, HPNA, etc.
- Consumer electronics begin to network.

Management of such convergence is complex, driving the need for simplification of end device provisioning and maintenance

**Challenge:** How to manage different elements within the home?

**Solution:** Essentially home networking represents a microcosm of all networking technologies and techniques that Conexant makes. Convergence is happening first in the home.

Today you need to be an IT expert (or have some teenagers in the house) to setup and configure your in-home networking devices. As addressed in the Industry, Applications and Technology Trends presentation, 30 – 50% of home networked devices are returned to the retailers with no trouble found. The users simply were unable to setup and configure the device using existing tools/software.

## Problems with the Existing Approach

Following are the problems with the existing approach.

### User Perspective

- No flexibility to buy any equipment off-shelf.
- No support from the service provider, if the equipment is bought.
- Devices are not plug-n-play requiring both ISP & user to do some configuration.
- Adding a new service requires both ISP & end-user coordination, which takes time.
- Requires customer presence at home, if truck roll is involved.
- Could be difficult to match as more couples are working nowadays.

### Service Provider Perspective

- Requires Truck Roll to activate any new services, troubleshooting and new installations. Each truck roll adds to a significant cost in terms of time and resources.

- When customer lodges a complaint, then it is very difficult for the “Helpdesk” to verify what is wrong with the CPE device by sitting in their office.
- Vendors provide their own proprietary solution, different interfaces, parameters and procedures. Hence the need for training per vendor solution.
- ISP forced to stick with a few chosen vendors because ISP has done custom automation to make their job easier. Switching to a new vendor may require changing custom automation.
- No way to discover the device-capabilities automatically and determine what parameters are supported.
- Not possible to determine if user-changed configuration information via local management interface like Web, CLI, or SNMP, etc.
- Not possible to prevent users from changing settings, which may affect the services offered by them.

## Services Offered by DSL Home – TR-69

---

Following are the list of services Offered by DSL Home – TR-69.

- Remote management of the devices in a secure manner (uses SSL/TLS based security).
- Real-time provisioning of services via auto-configuration.
- Status and performance monitoring.
- Diagnostics
- Access Control
- Notification
- Firmware upgrade
- Standardized data model tailored specially for CPE devices offering various services like voice, video, data and IPTV, etc. Includes wide coverage for LAN devices in the home segments (STB, VoIP, NAS) on different LAN technologies like – Ethernet, USB, WLAN, etc.
- Management protocol is to access technologies agnostics, thus it could be used for wide variety of CPE devices. For example – xPON, xDSL, etc., just requires the device to be IP addressable.
- Truckroll is minimized by Remote management.

- The Helpdesk can provide better services instead of just taking the complaint. Helpdesk has more context and can see complete configuration information about CPE from remote.
- No need to have vendor-specific training as data model is standardized for services so less need of training the staff.
- No custom automation required hence offering wider vendor base to choose from
- Provides automatic discovery of parameters available on the device.
- Provides Access control, hence allows prevention from user changing the specific configuration.
- Provides Notification mechanism, thus we get to know any change in configuration related to the services.
- Reduces Opex.
- Making it easier for Users & Service Providers to move beyond modems and best effort routers to triple/quad play services in digital home.

## TR69-Deployment Scenario

The following illustration depicts the TR69-Deployment Scenario.

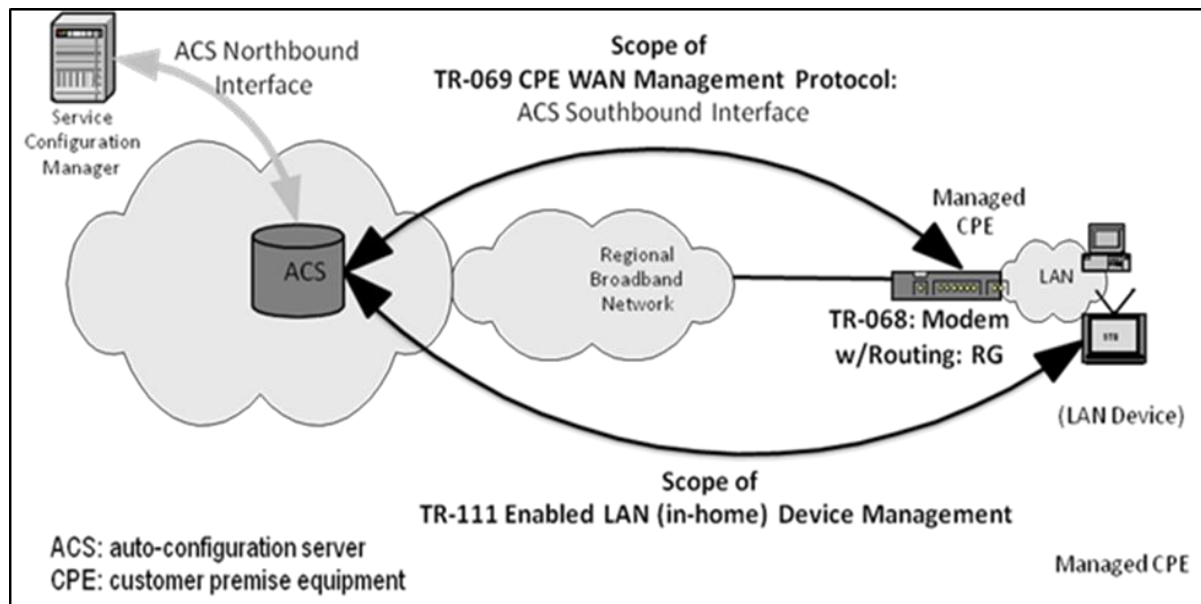

The TR69-Deployment will help with the following features:

- A secure networking solution to serve simultaneous users within the home
- Triple/Quad Play service (TV/video, telephony, Internet, wireless)
- Real-time provisioning of services via auto-configuration
- A mechanism to manage and automate support of such provisioning

The WT-124 => TR-068v2 adds new requirements that are based on expanded scope to include –

- Optical (PON) WAN side Ethernet port requirements
- Web redirection for diagnostic requirements
- DHCP Client requirements
- ACS initiated captive portal requirements.

Web redirection is needed when the network connectivity problems occur. The **RG MUST** provide a mechanism, which intercepts web browser pages (i.e. port 80 web page requests) and responds to these by directing the web browser to the appropriate internal web pages to identify and resolve network connectivity problems including, but not limited to:

- DSL cannot train. – Q. How to get this from the appropriate PHY port to the web?
- DSL signal not detected. – Q. Same question as above.
- Broadband Ethernet not connected (if applicable).
- ATM PVC not detected (if applicable).
- IEE 802.1x failure (if applicable).
- PPP server not detected (if applicable).
- PPP authentication failed (if applicable).
- DHCP not available.

### Example – TR-069 Protocol Functioning

The following illustration depicts the functioning of the TR-069 Protocol.

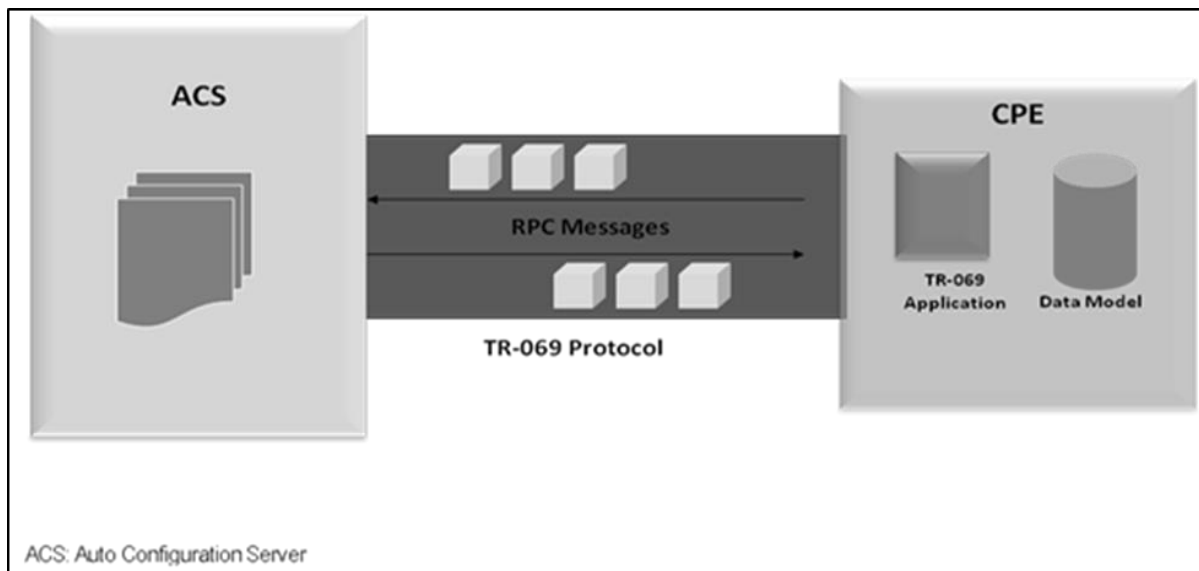

The above illustration is described in the following points.

- The TR-069 enables the configuration and management of end-user devices (RG, STB and VoIP). A significant difference in the DSL Forum approach is that TR-069 can go directly to the end-user device.
- **Connection** – Generic mechanism based on sending Remote Procedure Calls (RPC), which enables the ACS to read or write parameters to **config**, monitor and control the CPE. With RPC, SOAP messages (standard XML-based syntax), transported over a SSL/TLS (security layer), over HTTP, over TCP/IP connection, between CPE and a Management Server.
- **(Note)** – SNMP sends Protocol Data Units (PDUs) on top of UDP between a manager and an agent. The UDP is unreliable when compared to TCP, PDU size limited to the UDP frame size.
- **ACS Discovery** –
  - CPE can discover its associated ACS using DHCP.
  - Manual Configuration – CPE can be configured locally with the URL of ACS.
  - Default Configuration – CPE has a default ACS URL that it may use if no other URL is provided.
- **Session (Setup and teardown)** – A session ALWAYS initiated from CPE to the ACS using the pre-determined ACS address: issues the Inform RPC method for setup and Session TearDown, which closes the TCP connection when done.
- **(Note)** – SNMP does not support the concept of a session. Client needs to listen on a specified UDP port for messages from the server.
- **State Management** –
  - For sequence of transactions forming single session, CPE maintains TCP connection that persists for duration of the session.
  - When continuous TCP connection not possible, ACS uses session cookies to maintain a session state.
  - CPE returns information (cookie) set by the ACS in all the messages exchanged. At the end of the session, CPE terminates the associated TCP connection to the ACS and discards all cookies.

## Security

Security is enhanced with TR-069 by the CPE initiating all communication. The security TR-069 protocol supports following two security (level) mechanisms:

- SSL/TLS defines a certificate-based authentication between the CPE and ACS to provide a single secure connection
- The CPE can use the same x.509 certificate to provide encryption.



The client devices authenticated via the widely implemented HTTP authentication are as follows:

**TR-069 and End Devices:**

- TR-069 can be used by ACS for managing –
  - Residential Gateways (RG)
  - End Devices (ED) based on TR-111
- Two approaches –
  - RG acts as proxy for the ED
  - ED is managed directly by ACS

End of ebook preview  
If you liked what you saw...  
Buy it from our store @ <https://store.tutorialspoint.com>